

10.4" IP65 High Brightness Touch PC

- dustproof
- waterproof
- vandalism secure
- sunlight readable (1000+ Nits)

faytech's IP65 Sunlight readable, vandal-resistant aluminum Touch PC series has been designed for demanding industrial applications, especially outdoor or in places with much dust or water.

High-performance LEDs with extreme long life, coupled with specialty films and enhanced polarizers allow a perfect picture even under direct sunlight.

The individually equipped, water-and dust-resistant, highly stable connections ensure proper connectivity in all situations and withstand all weather conditions and application.

The heart of the system is faytech's renowned fay-002 mainboard series, equipped with reliable RAM, SSD and W-Lan modules. Preinstalled is an actual Linux Ubuntu Operating system, the fanless and rugged Touch-PC systems work out of the box.

The high-strength safety glass protects against vandalism, on the capacitive models nor a knife, nor a screwdriver leave any scratches.

These features make faytech's IP65 Touch-PC series a real globe-trotter. It is used in America in car wash centers (with capacitive touch panel), in Brazil in police cars (vandalism secure), in Australia in outdoor POS (high brightness), and in Asia and Europe in numerous industry projects. Rely in difficult and demanding operating areas on faytech's rugged touch-PC series.

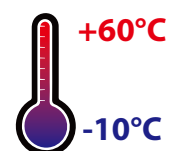

Product name	10.4" IP65 High Brightness Touch PC
Article code / EAN number	FT104N2807W2G64GIP65HB / 6920734010622

LCD Panel	
IP rating	IP65
Screen diagonal (Inch/cm)	10.4/26.42
Display active screen size	21.12x15.84
Aspect ratio	4:3
Physical resolution	1024x768
External Maximum showable resolution - DP	1920x1200
Colours displayed	16.7M
Brightness (cd/m ²)	1000+
Contrast	500:1
Typical reaction time Tr/ Tf (ms)	12.5/12.5
Visual Angle horizontal/vertical (°)	140/120
Backlight / Backlight Lifetime (hours)	LED / 40,000

Operation / Mechanical	
Operating Temperature (°C)	-10 ~ +60
Humidity Range (RH)	20%-90%
Net weight (kg)	1.80
Gross weight (kg)	2.60 (incl. cartonage)
Housing material	Aluminum
Housing (cm) LxWxH	28.40 x 23.70 x 6.30
Mounting	VESA 100

Internal Connectors
1x SO-DIMM Slot, max. 4GB, DDR3L-1333 Single channel memory
1x 12V DC power connector (2-pin)
1x 4-pin SATA power connector; 2x S-ATA 3GB/s ports
1x VGA pin header; 1x VGA pin header; 1x DP-Pin-Header
1x LVDS connector; 1x S/PDIF output pin header
1x 5-pin LCD power connector
1x Line-Out / Mic-In audio pin header
1x 4-pin (2x2W) audio amplifier connector
1x PS/2 keyboard/mouse connector (6-pin)
1x USB 2.0 header supports additional 4x USB 2.0 ports
2x RS232 connectors; 1x 8-bit Digital I/O interface
1x Chassis Fan connector

PC System	
CPU	Intel® Celeron™ DualCore N2807
Chipset	Intel® E3800
Graphic GPU	Intel® HD Graphics
Audio	Realtek 887 8 -channel high definition audio codec, Audio Amplifier EUA 2012A
Memory	1x 2GB DDR3L SODimm
Storage	faytech Industrial 64GB SSD
W-LAN	2x Realtek PCIe GB LAN 8111G
Driver Support	Win7/8/10; Linux; 32Bit/64Bit
Preinstalled OS	Linux Ubuntu

Touch Panel	
Touch Technology	5-Wire Resistive
Touch Connector	USB
Touch Panel Drivers	Windows; Linux; Mac; Android
Touch Life (Contacts)	10 million in 1 location without failure
Surface Hardness	3H

Power	
Power Indicator	Green LED
Power Supply	100-240V ACDC active switching; 12V DC-Out
Working Power (V)	12
Power Consumption (W)	26
Stand-By Consumption (W)	<0.5

External Connectors
1x 10/100/1000MB LAN
2x USB 2.0 / RS 232 serial
2x W-LAN antenna connector
1x 8-36V DC-IN

Expansion slots
2x Mini Card slots with PCIe and USB interface (2 x Full Height/Half height changeable)

Included in the Delivery
Power Supply (see Power section)
Driver DVD
Short Installation Manual
Stylus

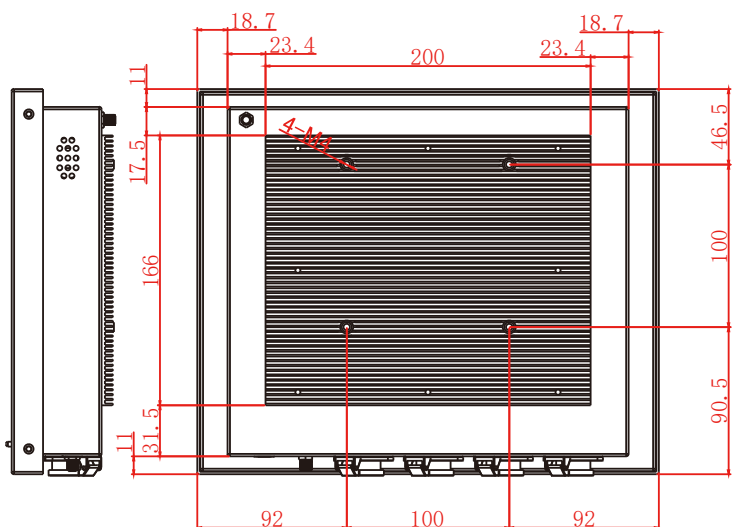
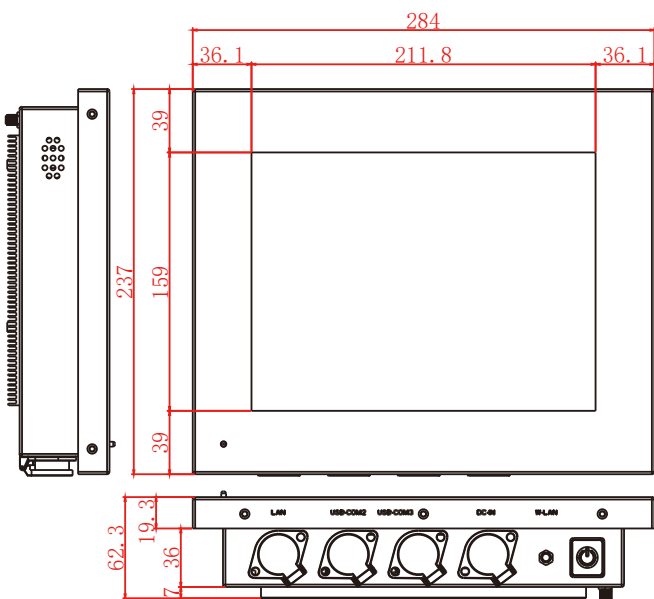

Corporate Headquarters

faytech Tech. Co., Ltd.
 Building F., Hongmen Tech. Zone,
 Jihua Rd., Shenzhen, China 518129

support@faytech.com
contact@faytech.com
www.faytech.com

China: +86 755 89580612
 Germany: +49 551 82098660
 USA: +1 646 205 3214